



FEATURES & BENEFITS





The Industry's Longest Warranty Coverage

Effective for units shipped from Everest from January 1, 2023. Applies to all **R290 units** except Glass Door Merchandiser Freezers, Laboratory Refrigerators/Freezers and Open Air Merchandisers.

Glass Door Merchandiser Freezers	Open Air Merchandisers and Laboratory Refrigerators/Freezers
<p>3 Years Parts & Labor Warranty</p> <p>5 Years Electrical Components Warranty^{1,2}</p> <p>5 Years Compressor Warranty²</p>	<p>2 Years Parts & Labor Warranty</p> <p>5 Years Electrical Components Warranty^{1,2}</p> <p>5 Years Compressor Warranty²</p>

¹ The Electrical Components Warranty applies to control boards, sensors, defrost heaters, evaporator/condenser fan motors, LED lights & power supplies, and door switches.

² Covers for parts only. Shipping & labor not included.

Compliance and Certification

Everest Refrigeration goes above and beyond when it comes to essential foodservice safety requirements. Our products meet the gold standards set by the most trusted certification bodies in the industry.

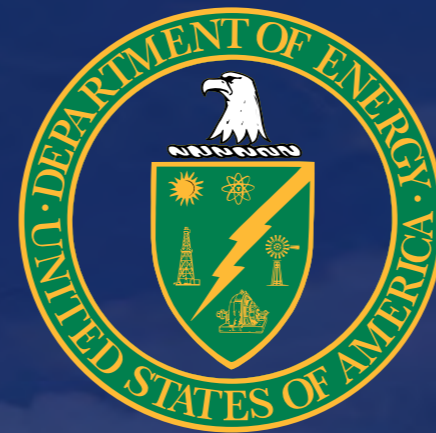

Production Facilities

INCHEON, SOUTH KOREA



Factory-1



Factory-2

Fully Automated Production



Full Product Line



Upright Reach-Ins



Dry Ager & Thawing Refrigerators



Glass Door Merchandisers



Open Air Merchandisers



Laboratory Refrigerators & Freezers



Undercounters



Chef Bases



Food Prep Tables



Bar Equipment



Countertop Refrigerated Display Cases



Industry's First

BLIZZARD R290

ALL-IN-ONE SLIDE-OUT COOLING CARTRIDGE



EPA / DOE Compliant

All Everest products are equipped with Blizzard R290.



Top Mount

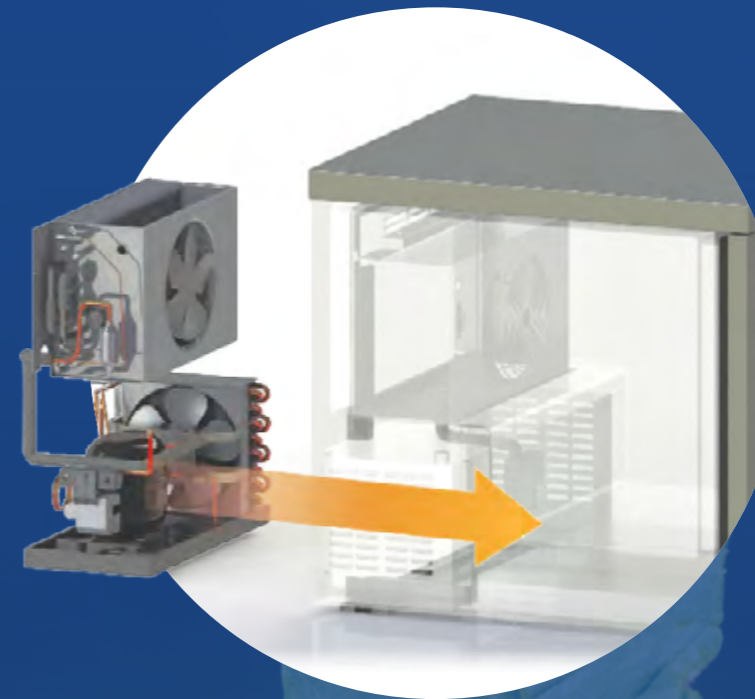

Back Mount

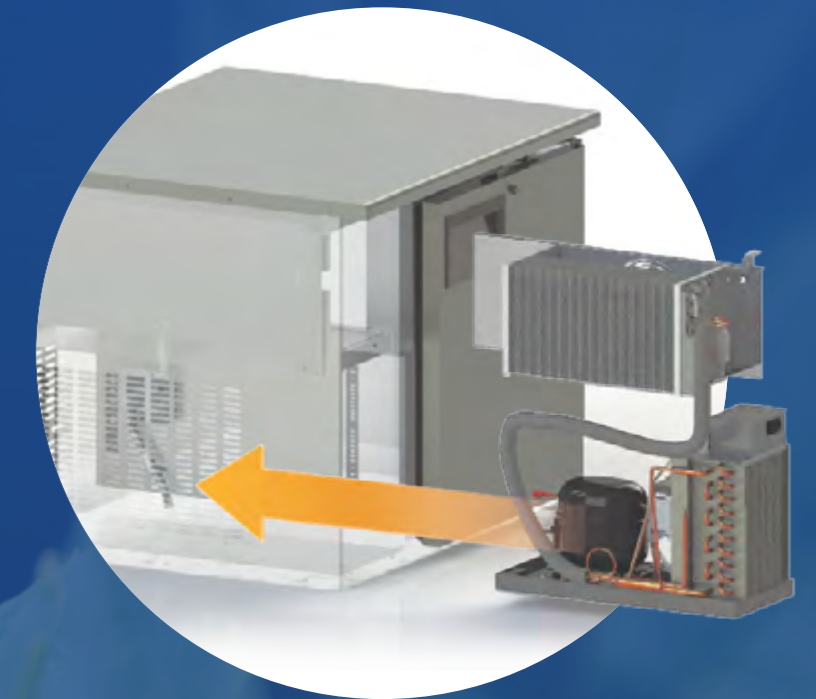

Side Mount



Bottom Mount



Zero Brazing

No brazing, soldering, or welding means no risk of fire.



Auto-Diagnostic System

Audio-visual alarms trigger at high temperatures.



30-Minute Replacement

Slide the old cartridge out, slide the new cartridge in.



Maintenance-Free

Auto-reverse fan helps keep the condenser coil clean.



Environmentally Safe

Uses EPA-approved, natural, hydrocarbon R290 refrigerant.

Standard Features



Blizzard R290

All-In-One, Slide-Out, Cooling Cartridge with EPA-approved natural refrigerant.



Self-Closing Doors

Air-tight torsion system for swing doors. Angled tracks for sliding doors.



All Stainless Steel

Exterior & interior for Reach-Ins, Prep. Tables, Undercounters, Chefbases & more.



Ridge-Lined Gaskets

Heavy duty door gaskets snap in for easy cleaning.



White/Black Coated Steel

Coated steel exterior & interior with stainless steel floor for Merchandisers.



Door Locks

Pre-installed for swing and sliding doors.



Textured Vinyl

Vinyl exterior with stainless steel worktop and interior floor for Bar Equipment.



Digital Controls

Easy to set temperature with audio-visual overheat protection alarm.



2.5" Thick Insulation

High-density polyurethane fill maintains temperature & conserves energy.



Energy Efficient Lights

Silicone coated or shielded LEDs with high color illumination & low heat output.

Upright Reach-Ins

Refrigerators / Freezers / Dual Temps

Top/Bottom Mounted Condensing Unit

ES & EB Series



All Stainless Steel

Interior & exterior with rounded corners for safety.



Reversible Doors

Easy factory or field reversal.

Vacuum Relief System

Equalizes cabinet pressure for smooth door re-entry.

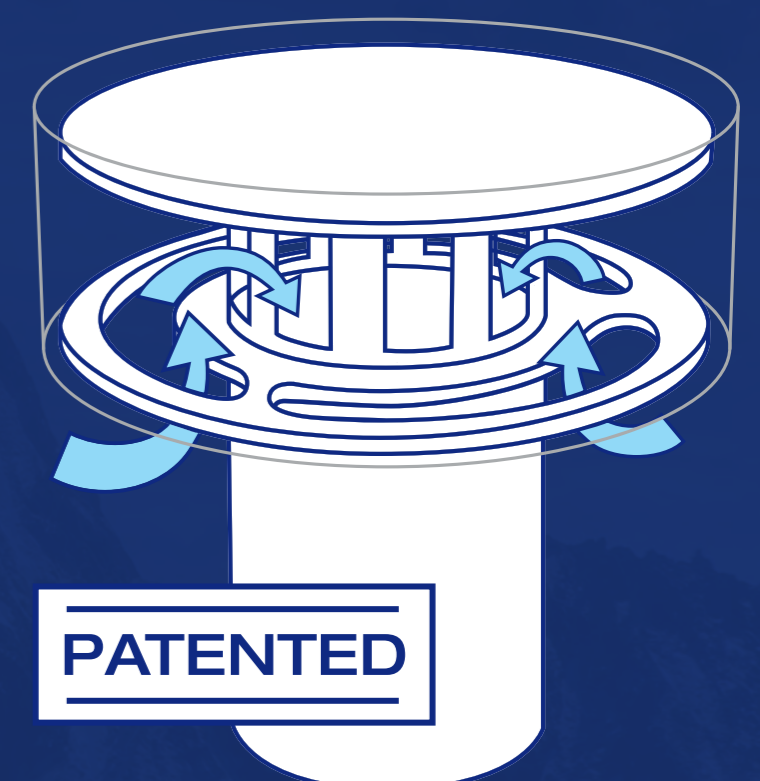

Dry Ager & Thawing Refrigerators

Refrigerators

Bottom Mounted Condensing Unit

ED Series



Improves Meat Quality

Ages fresh meat in a controlled environment, giving it richer flavor, texture and aroma.



Lab Certified Safe

Tested and certified safe by Certified Laboratories Inc.



Temperature Regulation

Pre-set to the perfect Dry Aging temperature allowing meat to mature without spoilage.



Cross Air Circulation

Maintains proper airflow and temperature-humidity ratio to speed up aging process.



Anion-Ceramic Coating

Diffuses infrared rays for proper maturation and keeps interior sterilized and odor-free.



Fast Dry Aging

Matures meat in only 7 days vs. 20-30 days with other brands.



DAY 2

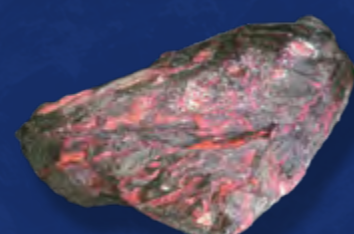

DAY 3

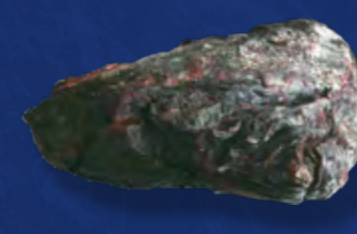

DAY 5



DAY 7

Glass Door Merchandisers

Refrigerators / Freezers

Bottom Mounted Condensing Unit

EM Series



Pre-installed Door Locks

Manual lock is standard for all sliding door models. Health Timer lock is optional for most swing door models.



Double Glass Pane Doors

Low emissivity and UV-reflective for efficient cooling.

Chromatography Features

Optional access ports, duplex GFCI outlet & NEMA 5-15P plugs.

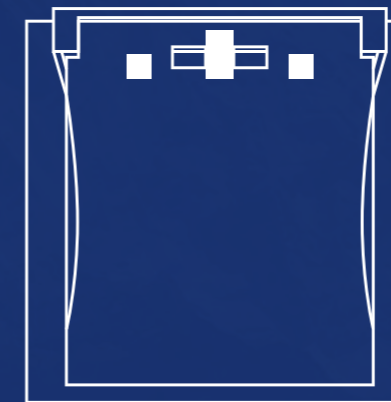

Covered Access Ports

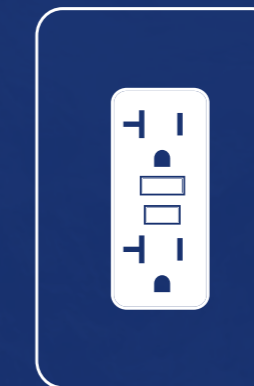

Duplex GFCI outlet



NEMA 5-15P Plugs



Open Air Merchandisers

Refrigerators

Bottom Mounted Condensing Unit

EOM Series



NSF7 Type II

Withstands a warmer ambient temperature of 80°F

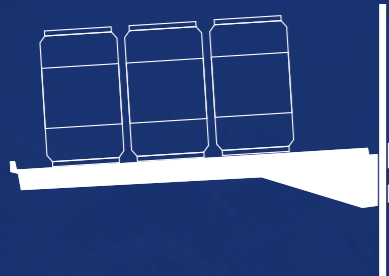

Adjustable Shelves

Height & tilt adjustable for better product visibility.



Built-In Night Curtain

Pulls down and latches for security & energy efficiency



Price Tag Moldings

Keeps price tag inserts neat and organized



EVEREST REFRIGERATION VS Other Brands

COMPARISON CHART OF STANDARD FEATURES

Standard Features	EVEREST REFRIGERATION	Turbo Air	Federal
80°F Max Ambient Temp. NSF7 TYPE II	✓		
All-In-One Slide-Out Cooling Cartridge	✓		
Price Tag Moldings	✓		
5" or 3" Casters	✓		
Fully Adjustable Shelves	✓		✓
All Stainless Steel Interior	✓	✓	
LED Lighting Under Shelves	✓	✓	
Built-in Night Curtain	✓	✓	✓
Shopping Cart Bumper Guard	✓	✓	
Self-Maintaining Condensate System (No Plumbing Required)	✓	✓	

Laboratory Refrigerators & Freezers

Refrigerators / Freezers

Bottom and Back Mounted Condensing Unit

LAB Series

Inverter Compressors

20% less energy consumption, stable cooling and precise temperature control

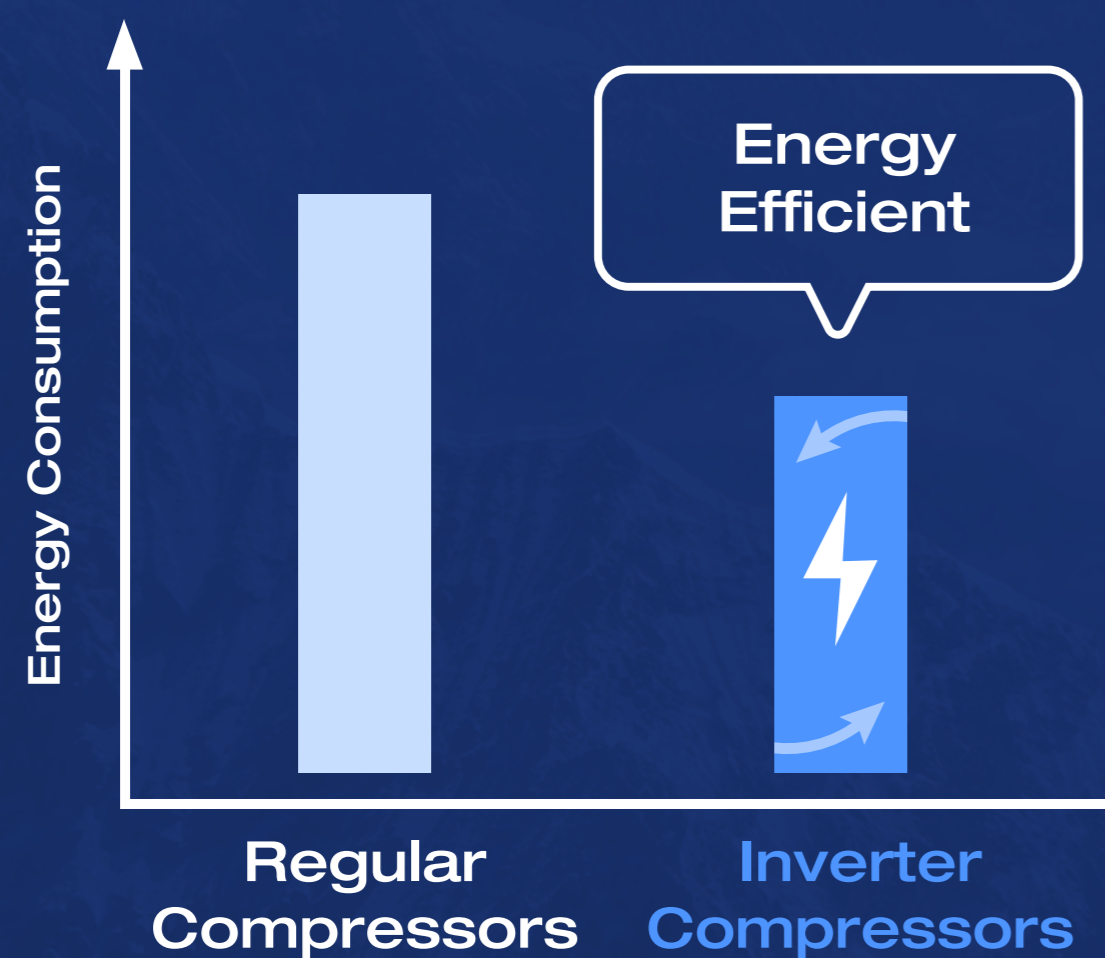

Electronic Keypad Lock

Auto-locks for security. Opens with a code or keycard.



Optional Data Logger & Monitor

Records real-time temperature. Sends email/text alerts. Smartphone/cloud compatible.



Undercounters

Refrigerators / Freezers / Dual Temps

Side & Back Mounted Condensing Unit

ET, ETG & ETB Series

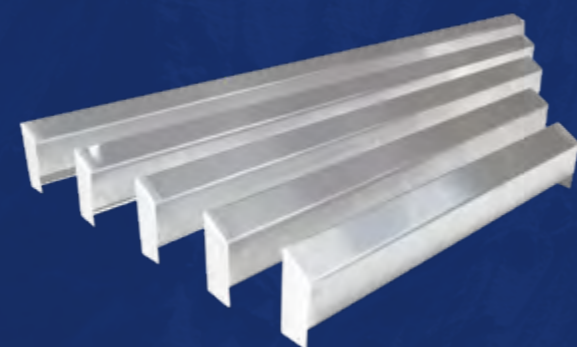

Optional Backsplash

Pre-installed & sealed 4" high stainless steel barrier.

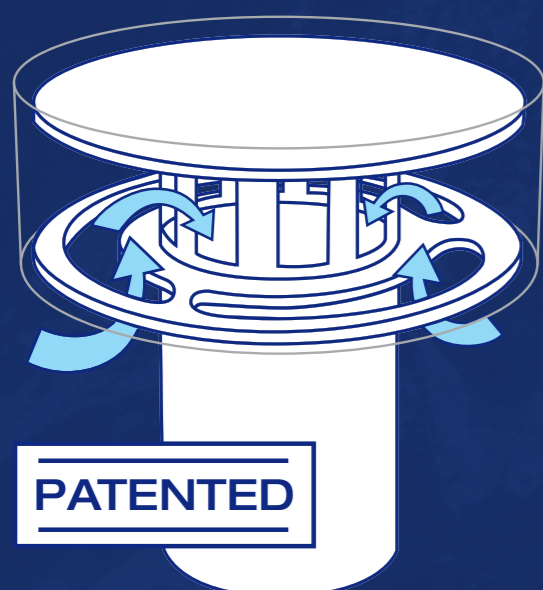

Vacuum Relief System

Equalizes pressure for smooth door re-entry.

Optional Overshelf

Stainless steel double overshelf for additional storage.

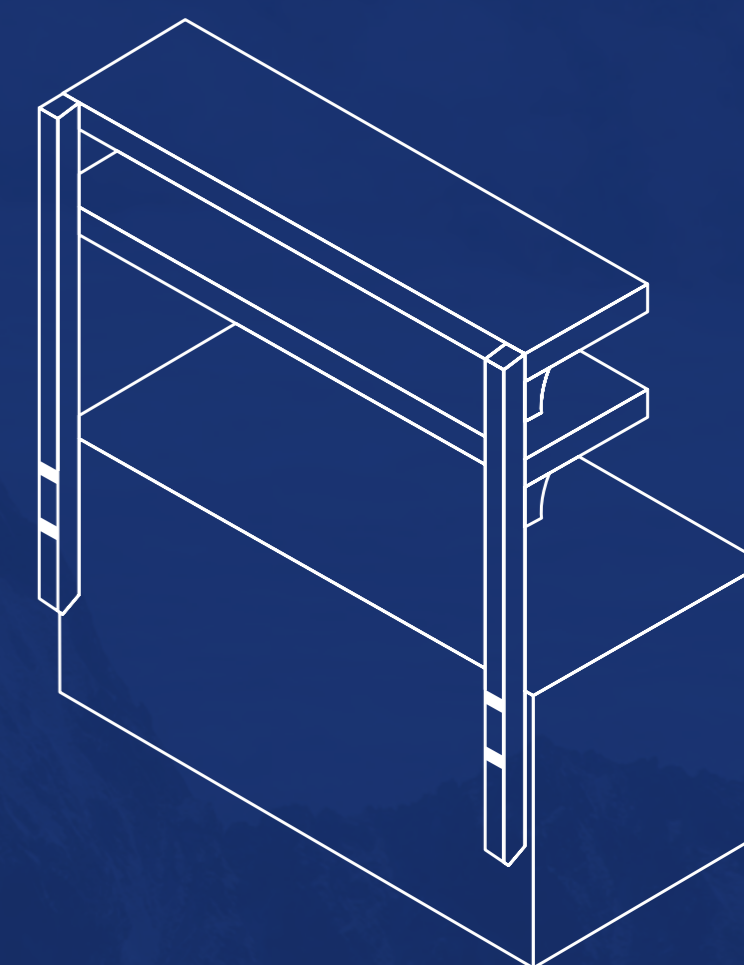

Chef Bases

Refrigerators

Side Mounted Condensing Unit

ECB Series



Reinforced Caster Brackets

Fully supports the added weight of mounted cooking equipment.

Heavy Duty Worktop

16-gauge top with heat protection will never warp from normal use.

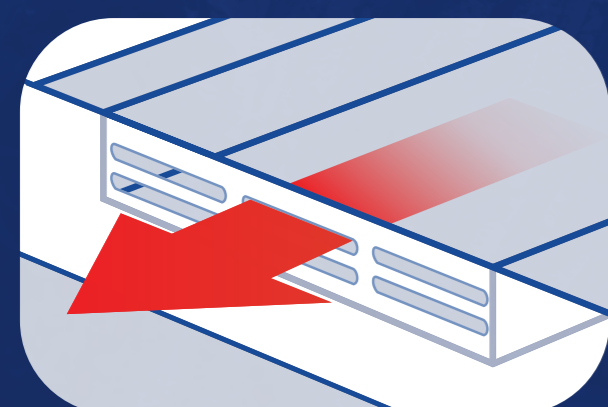

Air Chamber & Vents

Redirects and releases heat produced by mounted cooking equipment

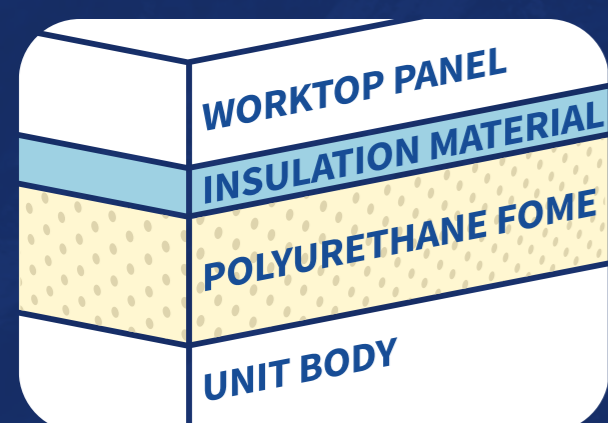

High Heat Insulation

Worktop insulation withstands temperatures of up to 500°F.

Heat produce by cooking equipment

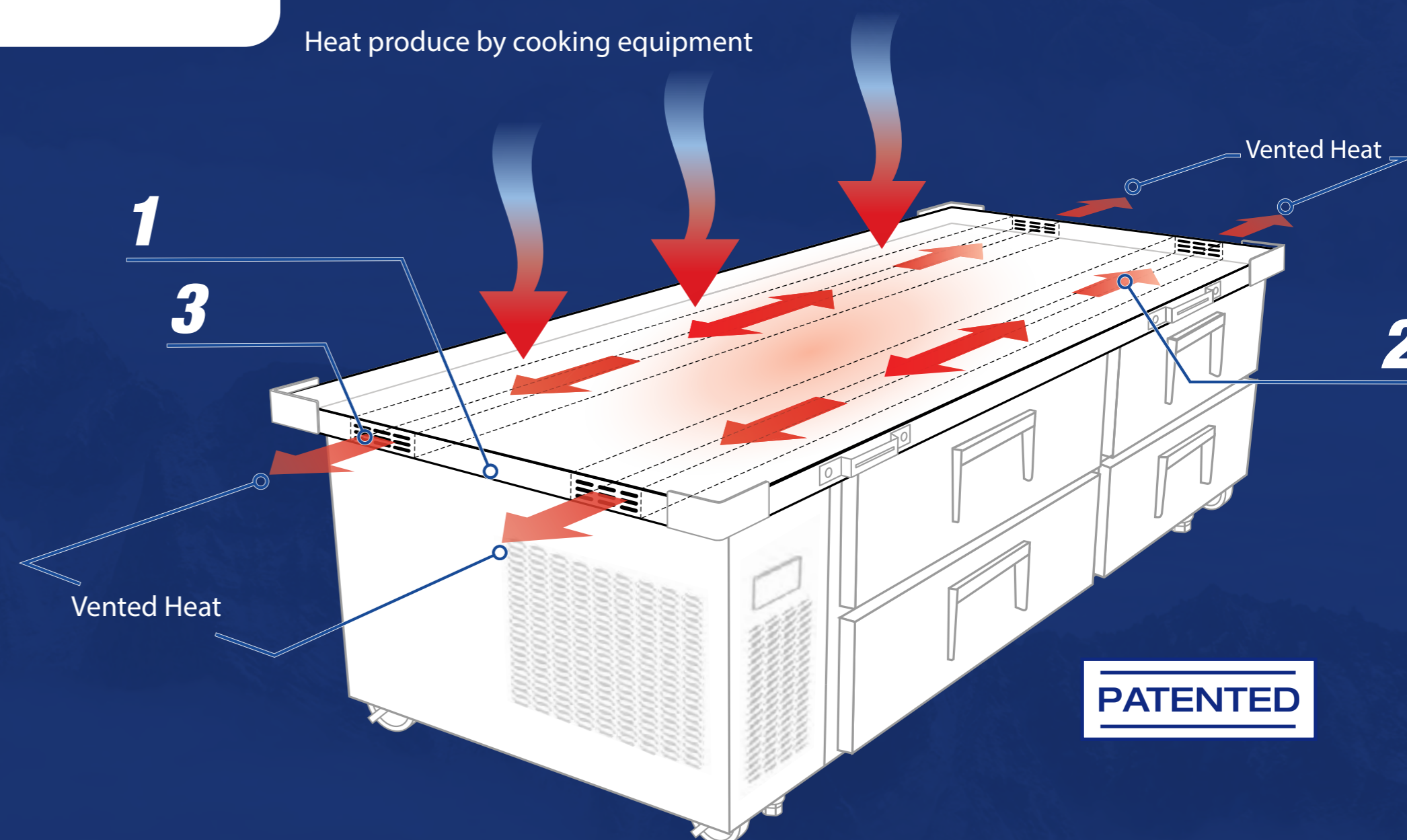

Food Prep. Tables

Refrigerators

Back Mounted Condensing Unit

EPB, EOTP, EP & EPP Series



Insulated Top Lid

Closes for top pan cold storage.
Props open when serving.



Adjustable Top Pans

Pan dividers are moveable to
accommodate varied top pan sizes.

Detachable Cutting Board

Board is extendable for more prep
space or removable for cleaning.

Optional Overshelf

Stainless steel double overshelf for
additional storage.

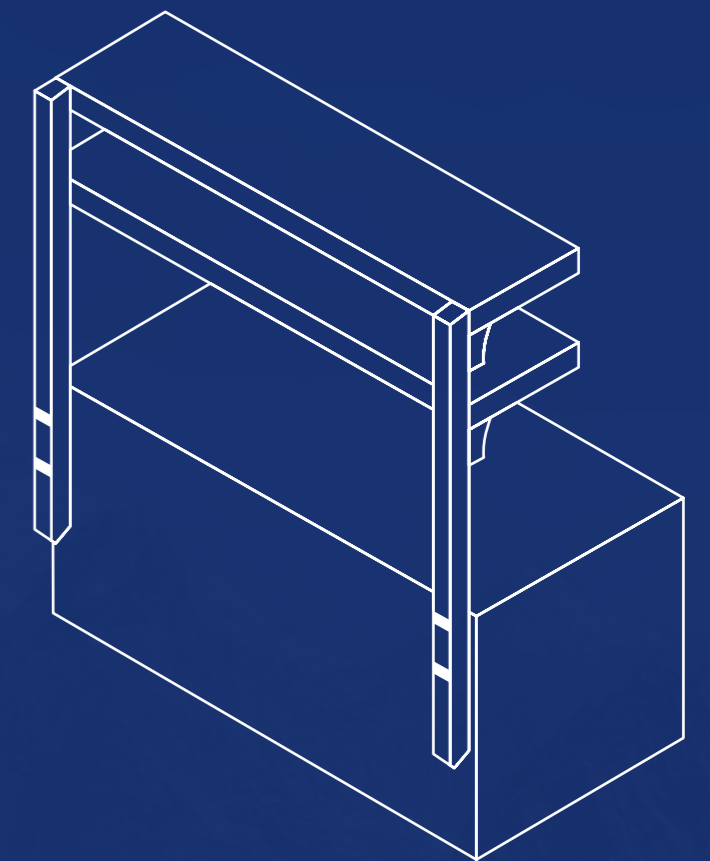

Bar Equipment

Refrigerators

Back & Side Mounted Condensing Unit

EBB, EBD, EGC & ECF Series

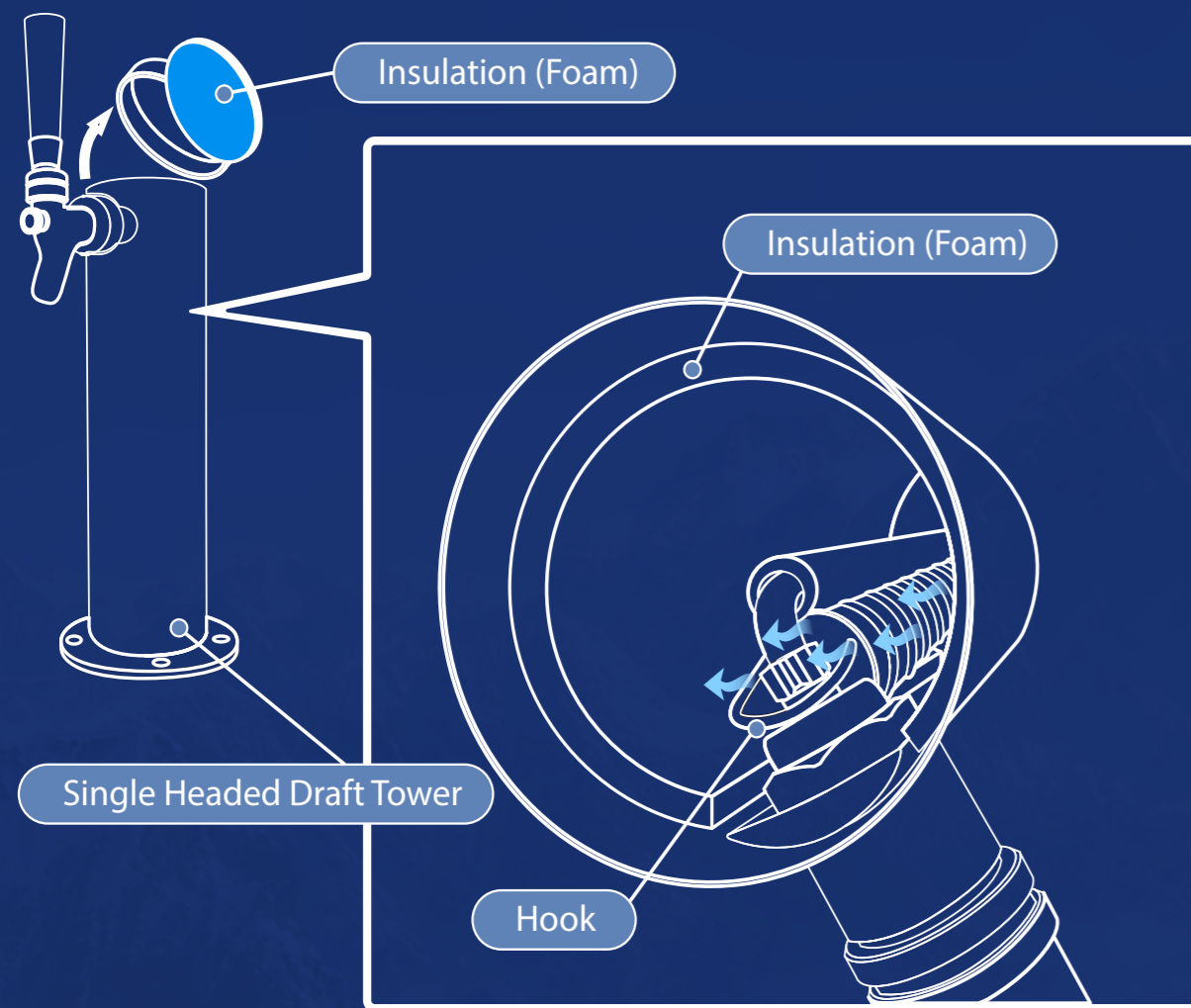

DRAFT TOWER INTERIOR

Reinforced Door Threshold

Protects interior door frame and floor when loading heavy contents.

Detachable Drip Tray*

Stainless steel tray is removable for easy cleaning.

Cold Air Hose*

Provides direct cooling to the draft tower for colder beer or coffee.

3/4" External Drain Port*

Compatible with standard hoses. Drain hose not included with unit.

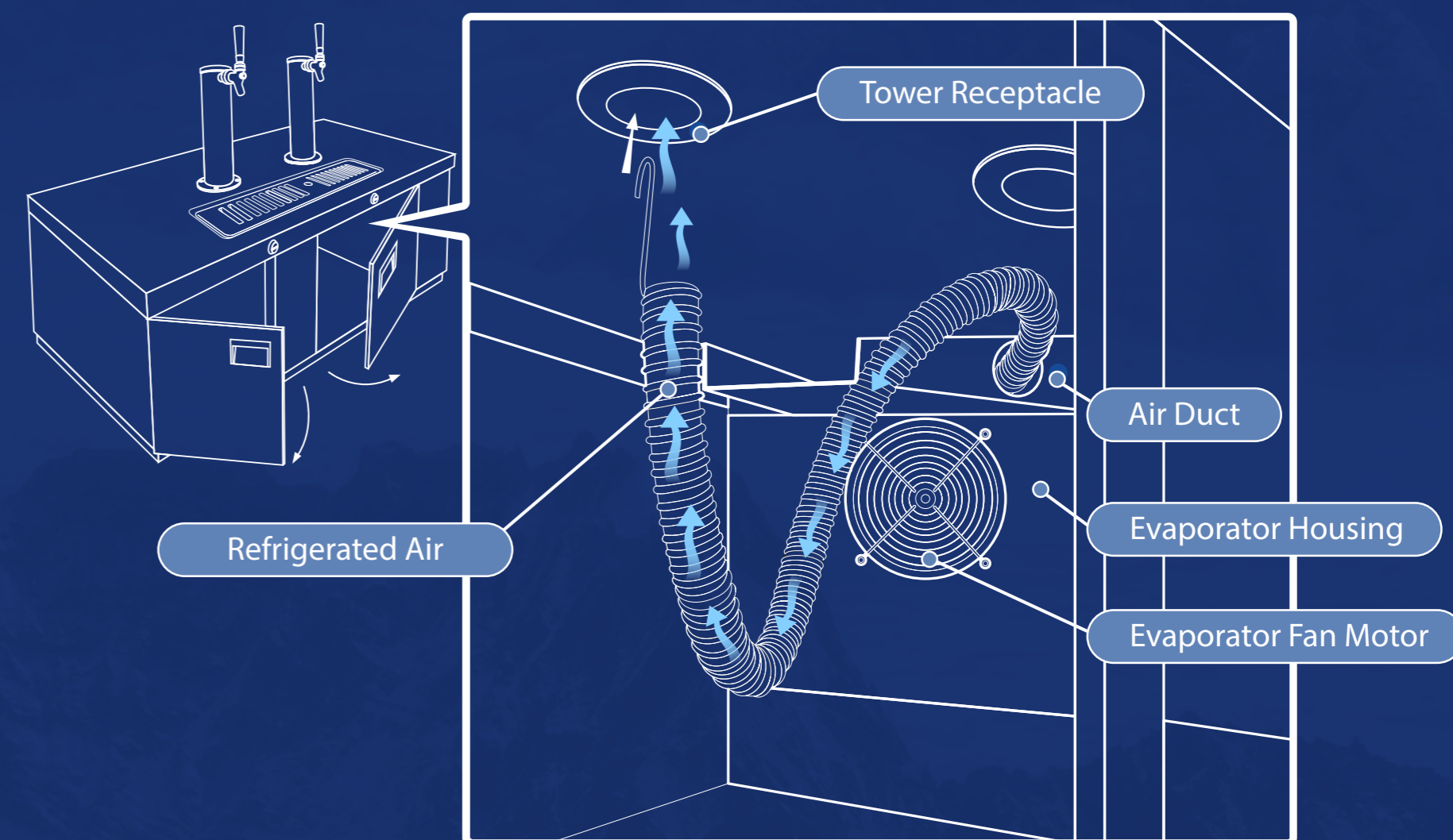

CABINET INTERIOR

*Applies to select models.

Countertop Refrigerated Display Cases

Refrigerators

Left & Right Condensing Unit

ESC Series



Top & Bottom Cooling Tubes

Provides balanced, all-around cooling for food items.



Energy Efficient LED Lights

Shielded LEDs with high lumen & low heat output

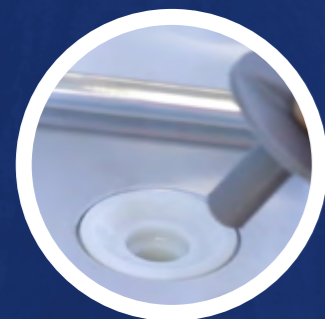

Exterior Drain Line

For easy cleaning of the display interior.

Adjustable Food Tray

Mounts two ways for low to medium temperature application.

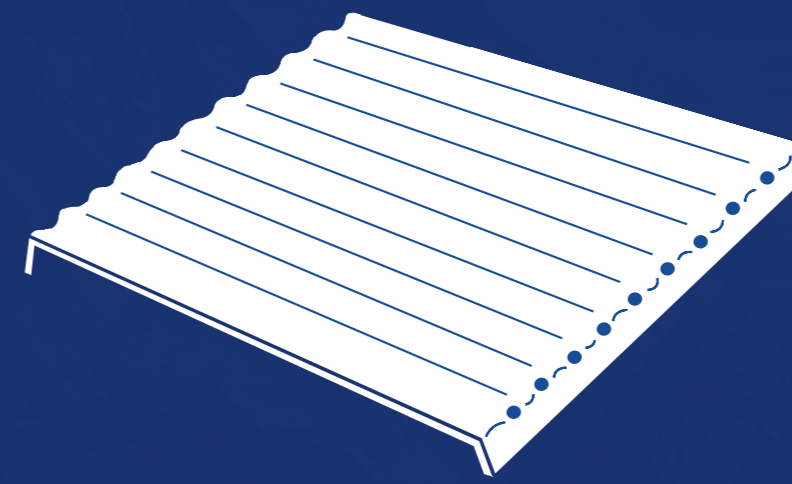

Medium Temperature

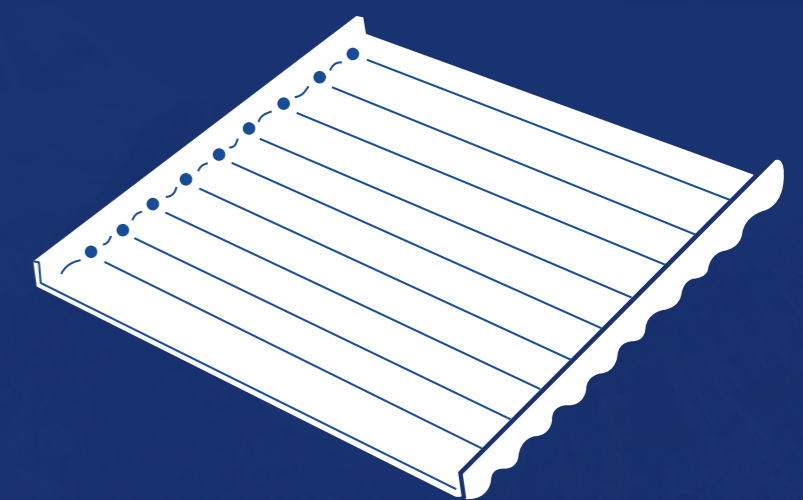

Low Temperature

