

DRAWERED UNDERCOUNTER REFRIGERATOR BACK MOUNTED CONDENSING UNIT



ETBR2-D4

ETB Series



Refrigeration System

- Back mounted, self-contained and fully detachable Blizzard R290 condensing unit uses environmentally friendly, EPA-compliant R290 refrigerant with zero (0) Ozone Depletion Potential (ODP) and three (3) Global Warming Potential (GWP). Blizzard R290 is easily replaceable and requires no on-site brazing.
- Front air breathing for flexibility in installation.
- Electronically commutated (ECM) fan motors achieve rapid cooling with less energy consumption.
- Full-length air duct ensures optimal cold air circulation.
- Time-initiated and temperature-terminated auto defrost cycle for seamless operation.
- Large capacity, corrosion-resistant condenser and evaporator coils.
- Self-maintaining, energy-efficient condensate drain pan requires no external drains or electric heaters.
- High performance, auto-reverse condenser fan motor supports compressor ventilation and condenser coil cleaning.
- Pressure relief devices allow rapid cabinet re-entry.
- Pre-wired and ready to plug, 115V/60Hz/1Ph, NEMA 5-15P.

Cabinet Construction

- Heavy duty stainless steel interior / exterior with rounded corners for a hazard-free workspace.
- Open spaced interior with no walls between compartments.
- 16 gauge, high quality stainless steel worktop.
- Galvanized steel bottom and rear.
- 2.5" thick high density polyurethane insulation.
- Four 5" swivel casters with locks on front set.

Doors

- Heavy-duty stainless steel interior / exterior.
- 2.5" thick high-density polyurethane insulation.
- Snap-in magnetic gaskets for ease of cleaning.
- High strength, recessed handles
- Thick gauge, stainless steel drawer frames with low-friction ball bearings.
- Drawer pans not included. See table for drawer pan capacity.

Shelving

- Height adjustable stainless steel clips.

Temperature Control

- Multi-function digital controller with easy to read LED display.
- Factory preset temperature, 35°F. Temperature setting range from 33°F to 54°F.
- Audible overheat protection alarm for compressor and condenser coil.

Options

- 4" high stainless steel backsplash for worktop application.
- 3" swivel casters with locks.
- 3.5" – 6" height-adjustable and interchangeable legs.
- NSF Certified Stainless Steel Double Overshelf.



Type	Doors	Capacity Cu. Ft.	# of Pans	Shelves	Refrigerant	HP	Power V-Hz-Ph	Amps	Crated Weight	Exterior Dimensions		
										L	D	H*
REF	4(DR)	14	1/2x4, 1/3x4, 1/4x2, 1/6x2*	-	R-290	1/5	115-60-1	2.6	299 lbs	47.5"	31.5"	30.125"

(†)Based on evaporating temperature of 23°F (-5°C) & condensing temperature of 131°F (55°C). (‡) Product capacity is calculated based on standard industry figures. (*) Reference plan view for clarification on caster/unit height. If dimensions and capacity are critical, please contact Everest Refrigeration. Blizzard R290 replacement is at the sole discretion of Everest Refrigeration. Specifications subject to change without notice.

DRAWERED UNDERCOUNTER REFRIGERATOR BACK MOUNTED CONDENSING UNIT



ETBR2-D4

ETB Series

DIMENSIONAL DATA

External Dims.	L	47.5 in.
	D	31.5 in.
	H*	30.125 in.
Crated Weight		299 lbs.
Doors/Drawers/Lids		4(DR)
Max Weight Support		-

STORAGE DATA

Net Capacity Cu. Ft. †	14
Shelves	-
Barrels	-
20 oz. Bottles	-
12 oz. Bottles	-
12 oz. Cans	-
8" Mugs	-
# of Pans (Top)	-
# of Pans (Drawer)	1/2x4, 1/3x4, 1/4x2,
Dividers	-
Trays	-

ELECTRICAL DATA

Voltage	115-60-1
Full Load Amperage	2.6A
Feed Wires w/ Ground	3
Cord Length	9ft
NEMA Plug Type	NEMA 5-15P

REFRIGERATION DATA

Compressor	Back
Refrigerant	R-290
Compressor HP	1/5
BTU/HR †	1655

KEY

D	Door	R	Refrigerator
L	Lid	REF	Refrigerator
H	Half Door	F	Freezer
FD	Full Door	FRZ	Freezer
SD	Solid Door	DUAL	REF/FRZ Combo
GD	Glass Door	DR	Drawer

	Elevation	Right	Plan	3D	Back

PLAN VIEW

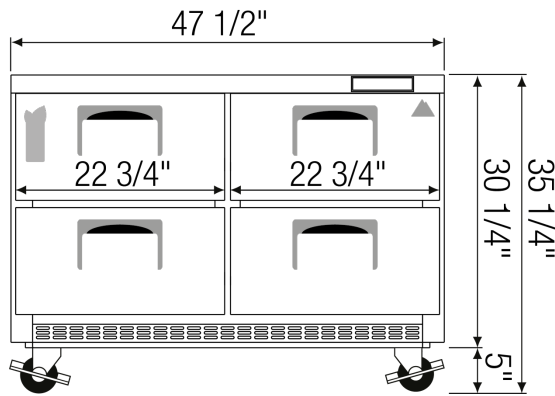

FRONT

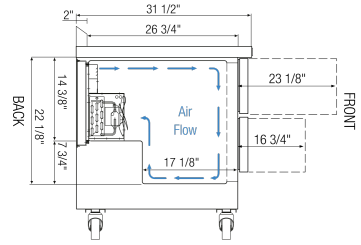

SIDE

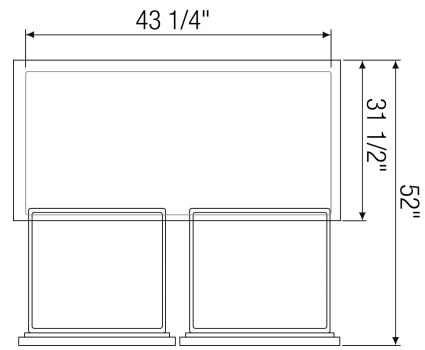

TOP

* Drawer pans not included

ACCESSORIES & OPTIONS

- AJL03-00 - Interchangeable Leg for Caster (Optional)
- BKSPL02-00 - 4" High (47-1/2" Long) Stainless Steel Backsplash
- CASA3-01 - 3" Overall Height Caster Assembly - (2) Front (2) Rear
- OS22-00 - Double overshelf (47" L x 13.5" D x 48" H). Adds 31" of height to unit.

(†)Based on evaporating temperature of 23°F (-5°C) & condensing temperature of 131°F (55°C). (‡) Product capacity is calculated based on standard industry figures. (*) Reference plan view for clarification on caster/unit height. If dimensions and capacity are critical, please contact Everest Refrigeration. Blizzard R290 replacement is at the sole discretion of Everest Refrigeration. Specifications subject to change without notice.