



ESC47L (Left Compressor Mount)
ESC47R (Right Compressor Mount, shown)



ESC59L (Left Compressor Mount)
ESC59R (Right Compressor Mount, shown)



ESC71L (Left Compressor Mount)
ESC71R (Right Compressor Mount, shown)



ESC83L (Left Compressor Mount)
ESC83R (Right Compressor Mount, shown)

Cabinet Construction

- Wide single piece, curved glass display window.
- Open spaced interior with no walls between compartments.
- Heavy duty, ABS plastic exterior casing.
- Black coated steel housing for condensing unit.
- Stainless steel floor interior has rounded corners and two drain holes for ease of cleaning.
- High density, foamed-in-place insulation.

Refrigeration System

- Self-contained condensing unit uses environmentally friendly, EPA-compliant R290 refrigerant with zero (0) Ozone Depletion Potential (ODP) and three (3) Global Warming Potential (GWP). Right or left mounted to suit installation preference.
- Rear condenser airflow intake and side louver exhaust promote efficient ventilation.
- Top to bottom evaporator tubes provide balanced cooling. Triple-looped and nickel plated copper tubing. Bottom coil is located under the interior flooring.
- Corrosion-resistant condenser coil.
- Electronically commuted (ECM) condenser fan motor achieve rapid cooling with less energy consumption.
- Removable and washable condenser coil air filter.
- Exterior on/off power switch.
- Pre-wired and ready to plug, 115V/60Hz/1Ph, NEMA 5-15P.

Doors

- 6 3/4" high removable sliding glass doors for storage accessibility and ease of cleaning.

Trays

- Durable plastic trays feature two mounting styles which offer medium to low temperature coverage.

Temperature Control

- Factory preset temperature of 38°F at an ambient temperature of 80°F (no controls equipped).
- NSF certified thermometer.

How to Use Plastic Trays

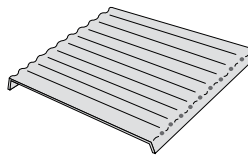

Medium Temperature Application

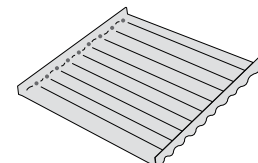

Low Temperature Application

Plastic trays offer medium to low temperature coverage depending on mounting style.

↔ = Interior Dimensions ↔ = Exterior Dimensions

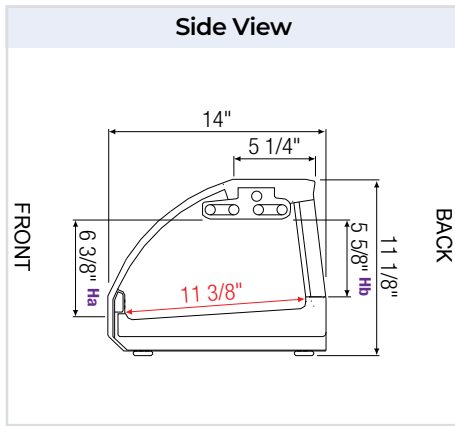

Equipped with 9 ft long NEMA 5-15P plug.

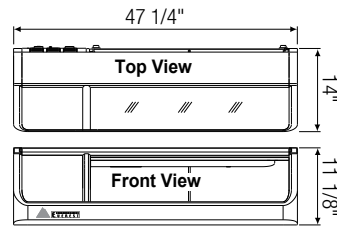

ESC47L

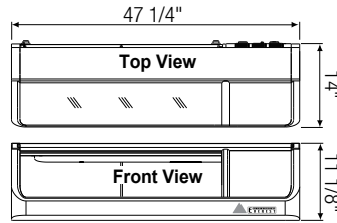

ESC47R

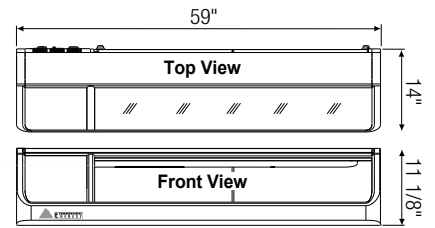

ESC59L

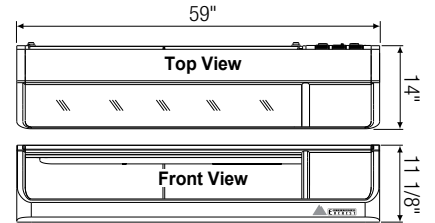

ESC59R

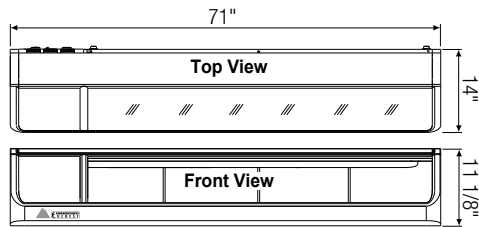

ESC71L

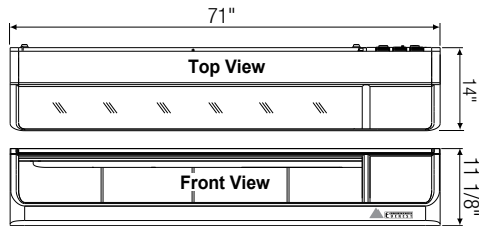

ESC71R

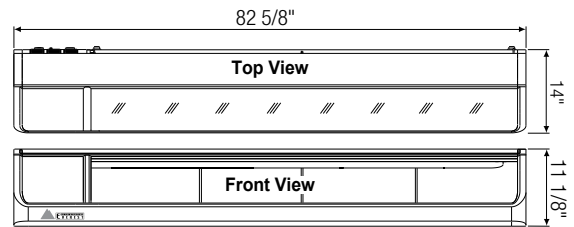

ESC83L

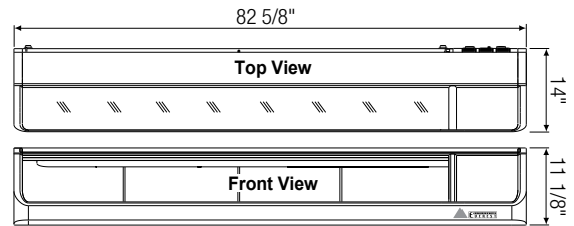

ESC83R

Model	Ref/ Frz/ Dual	Compressor Mount	# of Glass Doors	Capacity † (Cu. Ft.)	# of Trays	HP	BTU/HR †	Refrigerant	Power (V-Hz-Ph)	Amps	Crated Weight (LBS)	Exterior Dimensions (Inches)		
												L	D*	H
ESC47L	Ref	Left	2	1.5	3	1/6	1,211	R290	115-60-1	2.5	105	47 1/4	14	11 1/8"
ESC47R	Ref	Right	2	1.5	3	1/6	1,211	R290	115-60-1	2.5	105	47 1/4	14	11 1/8"
ESC59L	Ref	Left	2	2	4	1/6	1,211	R290	115-60-1	2.5	112	59	14	11 1/8"
ESC59R	Ref	Right	2	2	4	1/6	1,211	R290	115-60-1	2.5	112	59	14	11 1/8"
ESC71L	Ref	Left	4	2.5	5	1/6	1,211	R290	115-60-1	2.5	130	71	14	11 1/8"
ESC71R	Ref	Right	4	2.5	5	1/6	1,211	R290	115-60-1	2.5	130	71	14	11 1/8"
ESC83L	Ref	Left	4	3	6	1/6	1,211	R290	115-60-1	2.5	165	82 5/8	14	11 1/8"
ESC83R	Ref	Right	4	3	6	1/6	1,211	R290	115-60-1	2.5	165	82 5/8	14	11 1/8"

* Depth includes 1/4" for rear drain pipe.

† Based on evaporating temperature of 23°F (-5°C) & condensing temperature of 131°F (55°C).

Ha, Hb Interior Height

Specifications subject to change without notice.

Product dimensions are for general purposes and not absolute value. Product capacity (†) is calculated based on standard industry figures. Slight variations may exist. If dimensions and capacity are critical, please contact Everest Refrigeration.

Ref = Refrigerator