

# Club Top Direct Draw Keg Refrigerators

COMBINATION OF DRAFT BEER DISPENSER & CHILLED GLASS STORAGE EBD SERIES



EBD2-CT



EBD3-CT



EBD4-CT

## Cabinet Construction

- Heavy duty stainless steel countertop with textured laminate, black vinyl exterior.
- Open spaced interior with no walls between compartments.
- Galvanized steel interior walls and high quality stainless steel floor.
- Exterior T-shaped drain port routes excess moisture from the top tray. Drain hose not included. Floor drain required.
- 1 3/4" thick high density polyurethane insulation.
- Compact, easy-access club top compartment.
- Built-in caster thread receptacles for all models.

## Refrigeration System

- Side mounted R290 condensing unit uses environmentally friendly, EPA-compliant R290 refrigerant with zero (0) Ozone Depletion Potential (ODP) and three (3) Global Warming Potential (GWP).
- Electronically commutated (ECM) fan motors achieve rapid cooling with less energy consumption.
- Time-initiated and temperature-terminated auto defrost cycle for seamless operation.
- Large capacity, corrosion-resistant condenser and evaporator coils.
- Self-maintaining, energy-efficient condensate drain pan requires no external drains or electric heaters.
- High performance, auto-reverse condenser fan motor supports compressor ventilation and condenser coil cleaning.
- Pre-wired and ready to plug, 115V/60Hz/1Ph, NEMA 5-15P.

## Lighting

- Energy efficient silicone coated and shatter-proof LED lighting provides bright, high color illumination with low heat output.

## Doors & Lids

- Textured laminate, black vinyl exterior and galvanized steel interior with 1 3/4" thick high density polyurethane insulation for doors. Heavy duty stainless steel exterior and galvanized steel interior with 3/4" thick high density polyurethane insulation for cub top lids.
- Snap-in magnetic gasket for ease of cleaning.
- High strength door handles are recessed for doors and raised for club top lids.
- Pre-installed locks keep your items safe from theft.

## Shelving (Chilled Glass Storage)

- One epoxy coated, steel wire shelf.
- Height adjustable stainless steel clips.

## Draft Arms

- NSF certified, 3" diameter insulated stainless steel draft arm with matching air distributor. Two single faucet draft arms for model EBD2-CT. One single faucet and one dual faucet draft arms for model EBD3-CT. Two dual faucet draft arms for model EBD4-CT.

## Temperature Control

- Multi-function digital controller with easy to read LED display.
- Factory preset temperature, 35°F. Temp-set range from 33°F to 54°F.
- Audible overheat protection alarm for compressor and condenser coil.

## Options

- Dual or triple faucet draft arms and matching air distributors.
- Additional shelving.
- 3" or 5" swivel casters with locks.
- 3.5"-6" height-adjustable and interchangeable legs.

↔ = Interior Dimensions    ↔ = Exterior Dimensions

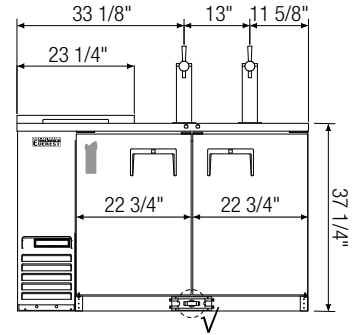
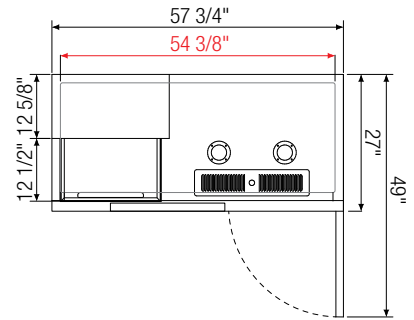
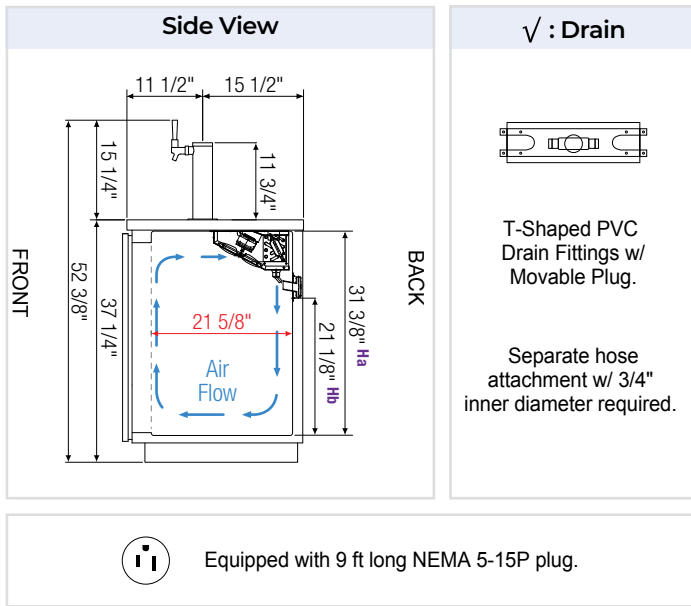

EBD2-CT

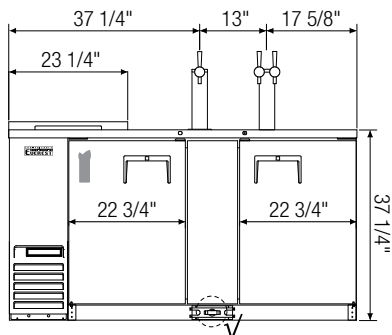
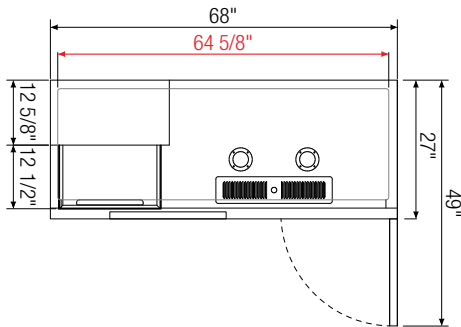

EBD3-CT

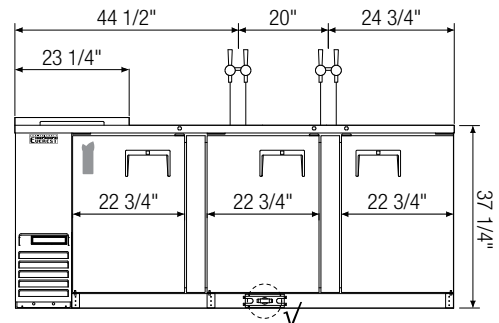
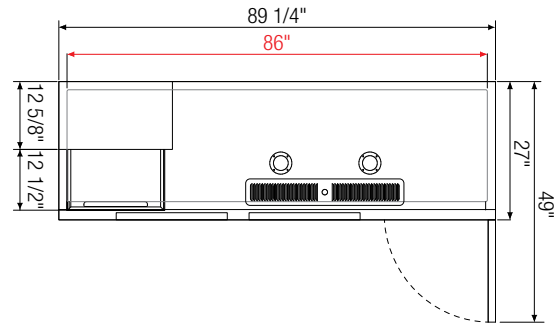

EBD4-CT

Model	Ref/ Frz/ Dual	# of Doors	# of Shelves	Capacity† (Cu. Ft.)	Capacity & Size of Barrels	HP	BTU/HR <sup>†</sup>	Refrigerant	Power (V-Hz-Ph)	Amps	Crated Weight (LBS)	Exterior Dimensions (Inches)		
												L	D	H
EBD2-CT	Ref	2	1	20	(2) 1/2	1/4+	1,926	R290	115-60-1	4	296	57 3/4	27	37 1/4
EBD3-CT	Ref	2	1	24	(3) 1/2	1/4+	1,926	R290	115-60-1	4	335	68	27	37 1/4
EBD4-CT	Ref	3	1	32	(4) 1/2	1/3	2,311	R290	115-60-1	2.5	450	89 1/4	27	37 1/4

† Based on evaporating temperature of 23°F (-5°C) & condensing temperature of 131°F (55°C).

Ref = Refrigerator

Ha, Hb Interior Height

Specifications subject to change without notice.

Product dimensions are for general purposes and not absolute value. Product capacity (†) is calculated based on standard industry figures. Slight variations may exist. If dimensions and capacity are critical, please contact Everest Refrigeration.