



**EBB48-24**



**EBB59-24**



**EBB69-24**



**EBB90-24**

## Cabinet Construction

- Heavy duty stainless steel countertop with textured laminate, black vinyl exterior.
- Open spaced interior with no walls between compartments.
- Galvanized steel interior walls and high quality stainless steel floor.
- 1 3/4" thick high density polyurethane insulation.
- Built-in caster thread receptacles for all models.

## Refrigeration System

- Side mounted, self-contained and fully detachable Blizzard R290 condensing unit uses environmentally friendly, EPA-compliant R290 refrigerant with zero (0) Ozone Depletion Potential (ODP) and three (3) Global Warming Potential (GWP). Blizzard R290 is easily replaceable and requires no on-site brazing.
- Electronically commutated (ECM) fan motors achieve rapid cooling with less energy consumption.
- Full-length air duct ensures optimal cold air circulation.
- Time-initiated and temperature-terminated auto defrost cycle for seamless operation.
- Large capacity, corrosion-resistant condenser and evaporator coils.
- Self-maintaining, energy-efficient condensate drain pan requires no external drains or electric heaters.
- High performance, auto-reverse condenser fan motor supports compressor ventilation and condenser coil cleaning.
- Pre-wired and ready to plug, 115V/60Hz/1Ph, NEMA 5-15P.

## Lighting

- Shielded LED bar lighting with on/off switch provides bright, high color illumination at lower heat output.

## Doors

- Textured laminate, black vinyl exterior with galvanized steel interior.
- 1 3/4" thick high density polyurethane insulation.
- Snap-in magnetic gasket for ease of cleaning.
- High strength, recessed handles.
- Pre-installed locks keep your items safe from theft.

## Shelving

- Two epoxy coated, steel wire shelves per section.
- Height adjustable stainless steel clips.

## Temperature Control

- Multi-function digital controller with easy to read LED display.
- Factory preset temperature, 35°F. Temp-set range from 33°F to 54°F.
- Audible overheat protection alarm for compressor and condenser coil.

## Options

- Additional shelving.
- 3" or 5" swivel casters with locks.
- 3.5"-6" height-adjustable and interchangeable legs.

↔ = Interior Dimensions   ← → = Exterior Dimensions

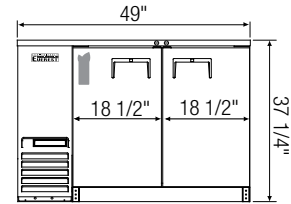
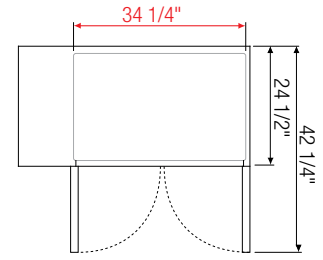
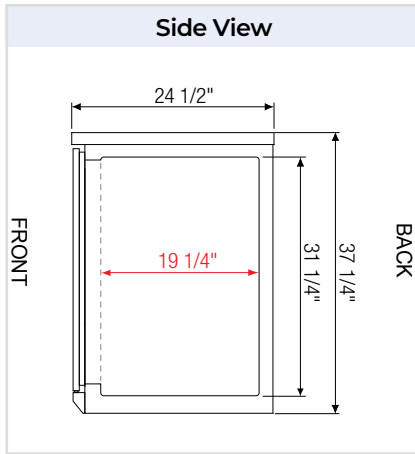
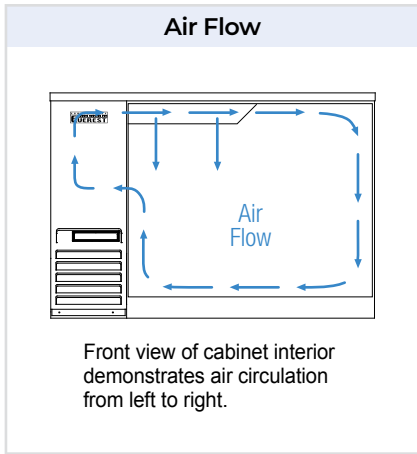

**EBB48-24**

ⓘ Equipped with 9 ft long NEMA 5-15P plug.

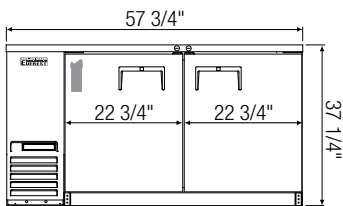
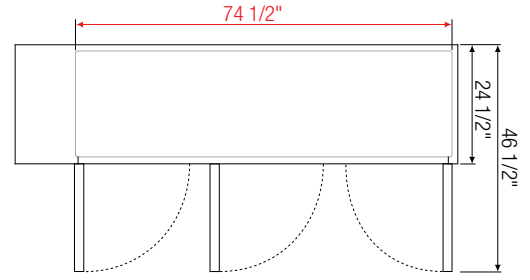
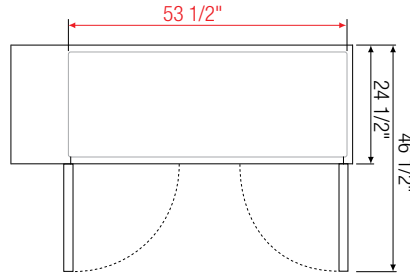
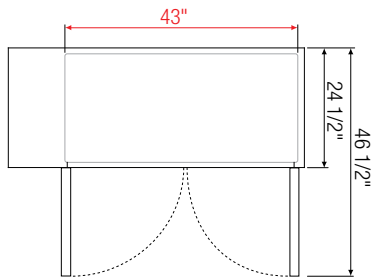

**EBB59-24**

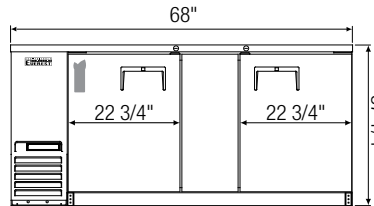

**EBB69-24**

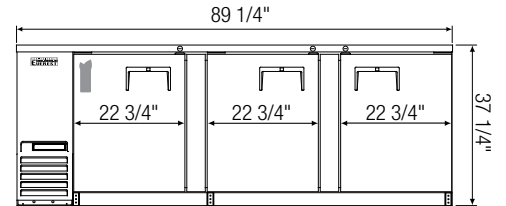

**EBB90-24**

Model	Ref/ Frz/ Dual	# of Doors	Capacity (Cu. Ft.)	Capacity		HP	BTU/HR <sup>†</sup>	Refrigerant	# of Shelves	Power (V-Hz-Ph)	Amps	Crated Weight (LBS)	Exterior Dimensions (Inches)		
				12 oz. Cans	12 oz. Bottles								L	D	H
<b>EBB48-24</b>	Ref	2	13	420	294	1/4+	1,926	R290	4	115-60-1	3.5	334	49	24 1/2	37 1/4
<b>EBB59-24</b>	Ref	2	17	560	357	1/4+	1,926	R290	4	115-60-1	3.5	274	57 3/4	24 1/2	37 1/4
<b>EBB69-24</b>	Ref	2	20	700	441	1/4+	1,926	R290	4	115-60-1	3.5	301	68	24 1/2	37 1/4
<b>EBB90-24</b>	Ref	3	28	980	609	1/3	2,311	R290	6	115-60-1	2.5	420	89 1/4	24 1/2	37 1/4

† Based on evaporating temperature of 23°F (-5°C) & condensing temperature of 131°F (55°C).

Ref = Refrigerator

Specifications subject to change without notice.

Product dimensions are for general purposes and not absolute value. Product capacity (†) is calculated based on standard industry figures. Slight variations may exist. If dimensions and capacity are critical, please contact Everest Refrigeration.